

Technical dishwashers

Model Number	LF73DWITU	LF065iTU	LFU-45iT
Programming			
Prewash	•	•	•
Normal (65°C)	•	•	•
Intensive (70°)	•	•	•
Economical	•	•	•
Express 15 minutes	•	•	•
Mixed	•	•	•
Quick Wash	•	•	•
Automatic	•	•	•
Hygienizer	•	•	•
Delicates	•	•	•
Total number of wash programmes	8	6	5
Number of temperature settings	6	4	4
Features			
Duo Zone (half load)	•	•	•
Electronic control	•	•	•
Number of place settings	12	12	10
Alternative wash	•	•	•
Condensor drying	•	•	•
Residual drying	•	•	•
Ecosensor	•	•	•
Variable consumption	•	•	•
Hot or cold water connection	•	•	•
Water hardness regulation levels	Automatic	5	•
High power descaler	•	•	•
Third spray sprinkler or spray arm	•	•	•
Self cleaning multi layer filter	•	•	•
Operating controls			
Delayed start	•	•	•
Programme pilot light	•	•	•
Time remaining display	•	•	•
Salt control pilot light	•	•	•
Rinse aid control light	•	•	•
End of programme signal	•	•	•
Start/Stop button	•	•	•
Baskets			
Height adjustable top basket	•	•	•
Height adjustable cup holder	•	•	•
Bottom basket with folding supports	•	•	•
Safety			
Hidden element	•	•	•
Aqua-stop	•	•	•
Anti-overflow	•	•	•
Aqua-control	•	•	•
Anti-water return	•	•	•
Anti-over heat	•	•	•
Dimensions			
Height adjustment on feet	•	•	•
Front adjustment of rear feet	•	•	•
Built-in H/W/D (mm)	820-890/600/600	820-890/600/600	820-870/450/600
Overall H/W/D (mm)	820-890/595/545	820-890/595/545	820/448/570
Packed H/W/D (mm)	855/665/665	855/665/665	860/494/661
Net weight (kg)	44	44	37
Gross weight (kg)	47	47	39
Technical specifications			
Energy efficiency	A	A	A
Wash efficiency	A	A	A
Drying efficiency	A	B	B
Noise level (dBA)	44	47	54
Water consumption per cycle (L)*	14	14	13
Electricity consumption per cycle (kWh)*	1.05	1.05	1.05
Duration (minutes)*	163	163	140
Annual water consumption (L)*	3520	3080	3520
Annual electricity consumption (kWh)*	231	231	231
Electrical Connection			
Total connected load (kW)	2.1	2.1	2.2
Connection	220-240V/50Hz	220-240V/50Hz	220-240V/50Hz
Supply rating (Amp)	13	13	10

• LF73DWITU LF065iTU

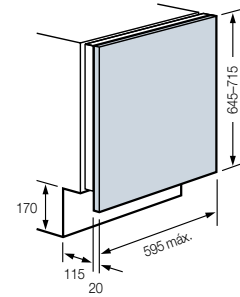
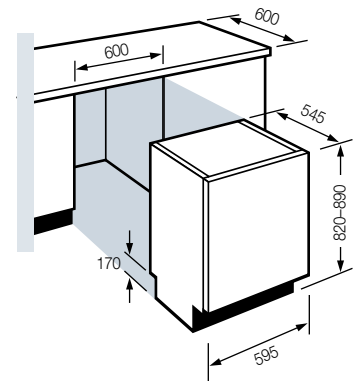

• LFU-45iT

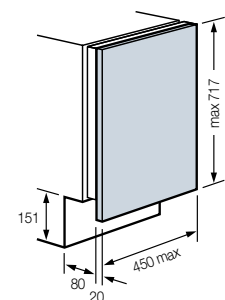
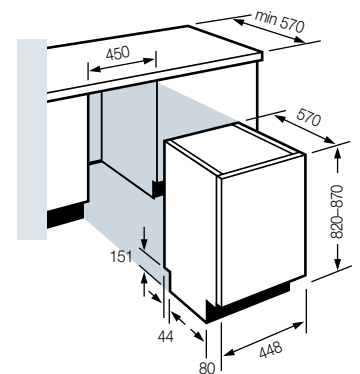

* Measured as per EN-50242 + Estimated average based on 220 washes