

Technical hoods

Model Number	3CFT-90ViSLA	7CFV-92X	CFFU-90X	CFFU-60X	1CC-130	7CFE-130iX	7CFG-60P
Hood Specification							
No. of motors	1	1	1	1	1	1	1
Control type	Electronic	Electronic	Slider	Slider	Slider	Slider	Cursor
Electronic speed control	•	•					
Intensive setting	•						
Extraction & recycling option	•	•	•	•	•	•	•
Saturation indicators	•	•					
Metal grease filter	•	•	•	•	•		•
Synthetic grease filters						•	
Hob illumination	x4 Halo	x2 40W	x2	x2	x1	x2	x2
Carbon filter	Optional	Supplied	Supplied	Supplied	Optional	Optional	Optional
Ducting dimensions (mm)	150/120	150/120	150/120	150/120	125	120	120
Performance data							
Fan speeds	4	3	3	3	3	3	3
Extraction rate m3/h max	800m3/h	800m3/h	450m3/h	450m3/h	350m3/h	300m3/h	280m3/h
Noise maximum setting dB(A)	48dB(A)	48dB(A)	52dB(A)	52dB(A)	45dB(A)	52dB(A)	59dB(A)
Installation							
Min height from gas hobs (mm)	700	700	700	700	700	700	700
Min height from electric hobs (mm)	550	550	650	650	650	650	650
Min height from induction hobs (mm)	400	400	400	400	400	400	400
Dimensions							
Maximum height (mm)	1340	1210	1140	1140	1320	400	n/a
Minimum height (mm)	1000	735	890	890	n/a	n/a	149
Width (mm)	1000	900	900	600	599	599	525
Depth (mm)	700	500	480	480	510	270	286
Packed H/W/D (mm)	580/120/820	1040/525/690	560/958/425	560/640/420	183/650/570	330/665/485	560/330/195
Net weight (kg)	36.5	24	13	9.7	5.5	9	4.9
Gross weight (kg)	50.5	28.1	15.2	11.3	6.5	11	5.5
Electrical Connection							
Total connected load (kW)	0.28	0.215	0.215	0.215	0.139	0.16	0.21
Connection	220-240V/50Hz	230V/50Hz	230V/50Hz	230V/50Hz	230V/50Hz	230V/50Hz	230V/50Hz
Fuse rating (Amp)	10	10	10	10	10	10	10

• 3CFT-90ViSLA

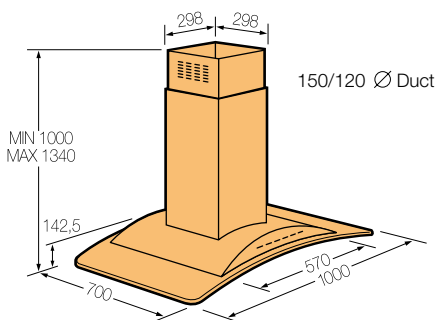

• 7CFV-92X

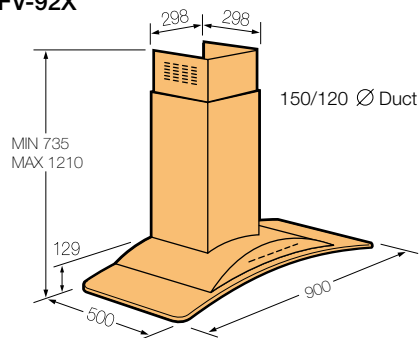

• CFFU-90X CFFU-60X

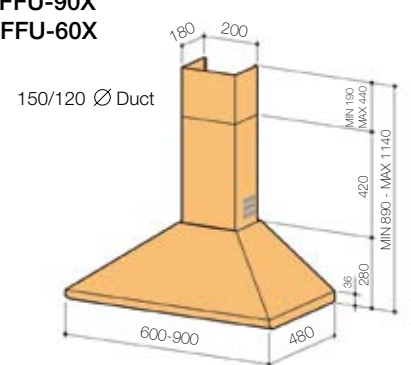

• 1CC-130

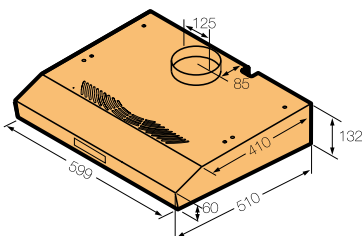

• 7CFE-130iX

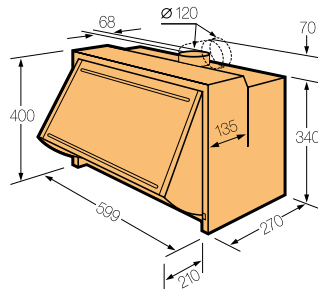

• 7CFG-60P

