

## Washing machines & Washer dryers

Model Number	FWM714iT	FU-6116iT	FWD612iT	FU-7814	FUS-6116
<b>Features</b>					
Maximum spin speed (R.P.M.)	1400	1100	1200	1400	1100
Wash load capacity (kg)	7	6	6	8	6
Drying capacity normals (kg)	na	na	4	na	4
Drying capacity delicates (kg)	na	na	1.5	na	1.5
Condenser drying (kg)	na	na	▪	na	▪
Electronic variable load	▪	▪	▪	▪	▪
Self cleaning filter	▪	▪	▪	▪	▪
Turbo time	▪	▪	▪	Plus	▪
ABS system	▪	▪	▪	▪	▪
Glass viewing window	▪	▪	▪	▪	▪
Polypropylene tub	▪	▪	▪	▪	▪
<b>Programs</b>					
Intensive	▪	▪	▪	▪	▪
Prewash	▪	▪	▪	▪	▪
Normals	▪	▪	▪	▪	▪
Delicates	▪	▪	▪	▪	▪
Mixed	▪	▪	▪	▪	▪
Wool	▪	▪	▪	▪	▪
Quick wash	▪	▪	▪	▪	▪
Cold	▪	▪	▪	▪	▪
Handwash	▪	▪	▪	▪	▪
Drying	▪	▪	▪	▪	▪
Cooling cycle	▪	▪	▪	▪	▪
Total number of programmes	16	16	16	16	16
<b>Controls</b>					
Single point program selector	▪	▪	▪	▪	▪
LCD display	▪	▪	▪	▪	▪
Delayed start	24 hour	24 hour	24 hour	24 hour	24 hour
Countdown indicator	▪	▪	▪	▪	▪
Pause wash	▪	▪	▪	▪	▪
Delicates	▪	▪	▪	▪	▪
Easy iron	▪	▪	▪	▪	▪
Intensive wash	▪	▪	▪	▪	▪
Extra rinse	▪	▪	▪	▪	▪
Time adjustment and end program	▪	▪	▪	▪	▪
Time remaining display	▪	▪	▪	▪	▪
<b>Safety</b>					
Overflow system	▪	▪	▪	▪	▪
Foam control	▪	▪	▪	▪	▪
<b>Dimensions</b>					
Built-in H/W/D (mm)	820/600/575	820/600/575	820/600/575	n/a	n/a
Overall H/W/D (mm)	850/590/550	850/590/550	818/596/511	850/590/590	850/590/590
Packed H/W/D (mm)	880/650/595	880/650/595	880/650/595	880/650/660	880/660/596
Net weight (kg)	67	67	73	75	75
Gross weight (kg)	69	69	80	78	78
<b>Technical specifications</b>					
Energy class	A++	A++	B	A+++	B
Wash performance	A	A	A	A	A
Spin performance	B	C	C	B	C
<b>Electrical Connection</b>					
Total connected load (kW)	2.2	2.2	2.2	2.2	2.2
Connection	220-240V/50Hz	220-240V/50Hz	220-240V/50Hz	220-240V/50Hz	220-240V/50Hz
Fuse rating (Amp)	13	13	13	13	13

## Steam Dryer

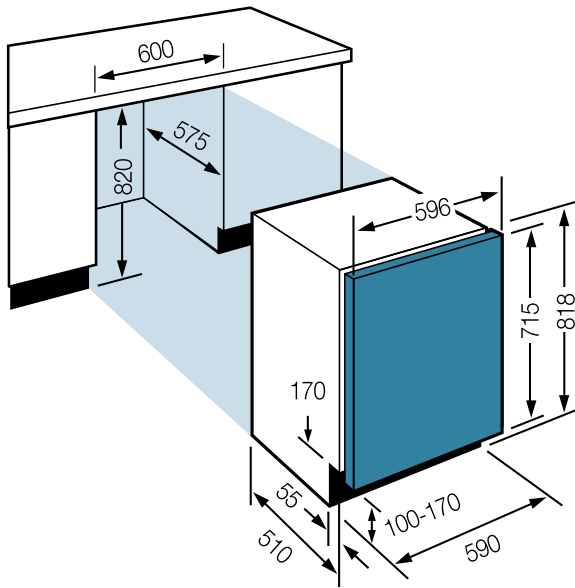

~ FWM714iT, FU-6116iT, FWD612iT

Model Number	FTD800W
<b>Features</b>	
Condenser drying	▪
Drum material	Stainless Steel
180° door opening	▪
Reversible door hinge	▪
Cover door / double door	▪
Door filter	▪
Removable condenser water tank	▪
Steam tank	▪
<b>Programs</b>	
Steam Drying:	
Cotton	▪
Synthetics / Mix	▪
Wool freshener	▪
Condenser Drying:	
Cotton - Extra dry	▪
Cotton - Dry	▪
Cotton - Ready to iron (damp)	▪
Mixed fabrics - Dry	▪
Mixed fabrics - Ready to iron (damp)	▪
Synthetics	▪
Delicates	▪
Wool	▪
Drying	▪
Total number of programmes	11
<b>Controls</b>	
Single point program selector	▪
LCD display	▪
Digital countdown indicator	▪
Delayed start	24 hour
ON / OFF	▪
Start / Pause programme	▪
End of cycle indicator (audible alarm)	▪
Full tank indicator	▪
Blocked filter indicator	▪
Empty steam tank indicator	▪
Tumbling option	▪
Additional drying option	▪
<b>Safety</b>	
Child lock	▪
Full tank safety (automatic stop)	▪
Empty tank safety (automatic stop)	▪
Anti over-heat	▪
<b>Dimensions</b>	
Built-in H/W/D (mm)	n/a
Overall H/W/D (mm)	850/600/600
Packed H/W/D (mm)	865/660/670
Net weight (kg)	38
Gross weight (kg)	40
<b>Technical specifications</b>	
Energy efficiency class	B
Drying capacity - condenser drying (kg)	8
Drying capacity - steam drying (kg)	2
<b>Electrical Connection</b>	
Total connected load (kW)	2.7
Connection	220-240V/50Hz
Fuse rating (Amp)	13