

# Hoods

| Model Number                        | 6CFT-90ViSLA  | 9CFV92X     | 9CFD90X     | 9CFD60X     | 9CFC52X     | 7CFE-130iX  | 7CFG-60P    |
|-------------------------------------|---------------|-------------|-------------|-------------|-------------|-------------|-------------|
| <b>Hood Specification</b>           | <b>100cm</b>  | <b>90cm</b> | <b>90cm</b> | <b>60cm</b> | <b>52cm</b> | <b>60cm</b> | <b>52cm</b> |
| No. of motors                       | 1             | 1           | 1           | 1           | 1           | 1           | 1           |
| Control type                        | Electronic    | Electronic  | Push        | Push        | Slider      | Slider      | Cursor      |
| Electronic speed control            | •             | •           | •           | •           | •           | •           | •           |
| Extraction & recycling option       | •             | •           | •           | •           | •           | •           | •           |
| Metal grease filter                 | •             | •           | •           | •           | •           | •           | •           |
| Synthetic grease filters            | •             | •           | •           | •           | •           | •           | •           |
| Hob illumination                    | x4 Halo       | x2 20W      | x2          | x2          | x1 40W      | x2          | x2          |
| Carbon filter                       | Optional      | Supplied    | Supplied    | Supplied    | Supplied    | Optional    | Optional    |
| Ducting dimensions (mm)             | 150/120       | 150/120     | 150/120     | 120         | 125         | 120         | 120         |
| <b>Performance data</b>             |               |             |             |             |             |             |             |
| Fan speeds                          | 3             | 3           | 3           | 3           | 3           | 3           | 3           |
| Extraction rate (CECED) m3/h max    | 830m3/h       | 850m3/h     | 610m3/h     | 610m3/h     | 225m3/h     | 210m3/h     | 210m3/h     |
| Noise maximum setting dB(A)         | 69dB(A)       | 70dB(A)     | 68dB(A)     | 68dB(A)     | 58dB(A)     | 58dB(A)     | 60dB(A)     |
| <b>Installation</b>                 |               |             |             |             |             |             |             |
| Min height from gas hobs (mm)       | 650           | 650         | 700         | 650         | 700         | 700         | 700         |
| Min height from electric hobs (mm)  | 550           | 550         | 650         | 550         | 650         | 650         | 650         |
| Min height from induction hobs (mm) | 400           | 400         | 400         | 400         | 400         | 400         | 400         |
| <b>Dimensions</b>                   |               |             |             |             |             |             |             |
| Maximum height (mm)                 | 1052          | 1074        | 1080        | 1080        | 140         | 400         | n/a         |
| Minimum height (mm)                 | 692           | 821         | 700         | 700         | n/a         | n/a         | 149         |
| Width (mm)                          | 999           | 900         | 900         | 600         | 600         | 599         | 525         |
| Depth (mm)                          | 700           | 500         | 500         | 500         | 510         | 270         | 286         |
| Packed H/W/D (mm)                   | 555/1065/775  | 570/950/460 | 560/960/380 | 560/655/375 | 190/650/560 | 330/665/485 | 560/330/195 |
| Net weight (kg)                     | 28.65         | 19          | 13          | 11.5        | 6.5         | 9           | 4.9         |
| Gross weight (kg)                   | 40.9          | 23          | 15          | 12.5        | 7.5         | 11          | 5.5         |
| <b>Electrical Connection</b>        |               |             |             |             |             |             |             |
| Total connected load (kW)           | 0.33          | 0.370       | 0.215       | 0.205       | 0.160       | 0.16        | 0.21        |
| Connection                          | 220-240V/50Hz | 230V/50Hz   | 230V/50Hz   | 230V/50Hz   | 230V/50Hz   | 230V/50Hz   | 230V/50Hz   |
| Fuse rating (Amps)                  | 10            | 10          | 10          | 10          | 10          | 10          | 10          |

~ 6CFT-90ViSLA

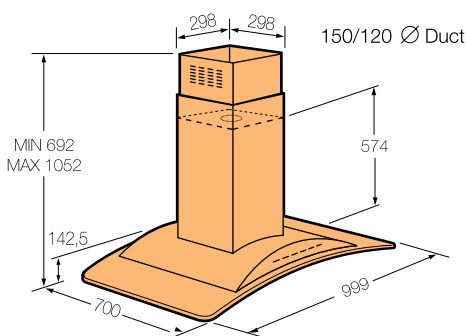

~ 9CFV92X

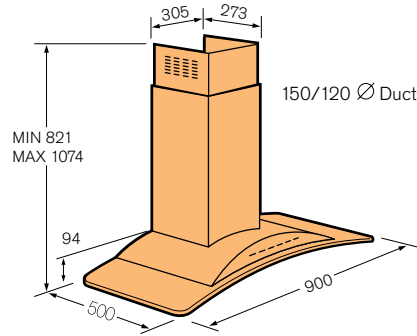

~ 9CFD90X  
~ 9CFD60X

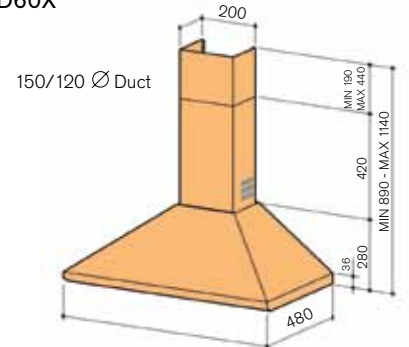

~ 9CFC52X

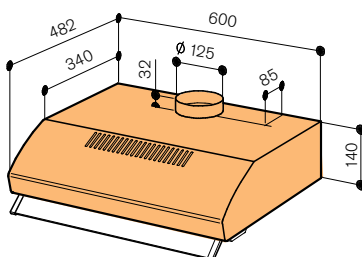

~ 7CFE-130iX

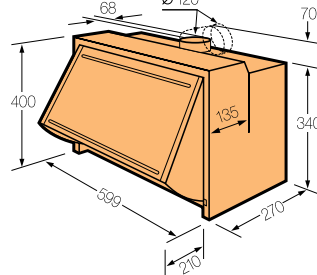

~ 7CFG-60P

