

Cooling

Model Number	3FiC-370	FiC-541/UK	FiS-810	CiV-820
Capacity				
Gross volume refrigerator (litre)	192	142	136	na
Usable volume refrigerator (litre)	189	141	133	na
Gross volume freezer (litre)	84	112	na	115
Usable volume freezer (litre)	75	98	na	86
Total gross volume (litre)	276	254	136	96
Total usable volume (litre)	264	239	133	86
General features				
Compressors	1	1	1	1
Reversible doors	▪	▪	▪	▪
Side by side combinations	na	na	▪	▪
Antibacteria Biocare inner liner		▪		
Refrigerator features				
Listeria thermostat			▪	na
Vegetable tray	glass	glass	glass	na
Hidden evaporator	▪	▪	▪	na
Automatic cyclical defrosting	▪	▪	▪	na
Automatic evaporation	▪	▪	▪	na
Interior light	▪	▪	▪	na
Bottle shelves	▪	▪	▪	na
Egg rack	1	1	1	na
Number of trays	4	3	2	na
Glass shelves	3	3	2	na
Vegetable drawers	2	1	1	na
Drain	▪	▪	▪	na
Door balconies	4	5	2	
Freezer features				
Drawers	3	4	na	3
Ice trays	▪	1	na	1
4-star freezer	▪	▪	na	▪
Dimensions				
Built-in H/W/D (mm)	1776/560/555	1776/560/555	820-880/600/550	820-880/600/550
Overall H/W/D (mm)	1770/540/545	1775/540/545	819-889/595/548	819-889/596/545
Packed H/W/D (mm)	1834/584/600	1835/585/650	883/659/586	880/635/600
Net weight (kg)	56	62	31.5	33
Gross weight (kg)	62	64	34.5	35
Door fitting	Slider System	Slider System	Door on Door	Door on Door
Consumption				
Climate Class ⁺	SN-ST	SN	N	N
Energy Class	A	A	A	A+
Electricity consumption (kWh/24h)	0.86	0.86	0.41	0.5
Electricity consumption (kWh/year)	314	314	150	182
Freezer power (kg/24h)	6	8	na	8
Gas	R600a	R600a	R600a	R600a
Electrical Connection				
Total connected load (W)	140	140	100	90
Connection	220-240V/50Hz	220-240V/50Hz	220-240V/50Hz	220-240V/50Hz
Fuse rating (Amp)	13	13	13	13

~ 3FiC-370

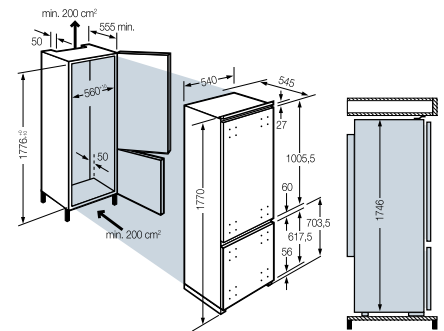

~ FiC-541UK

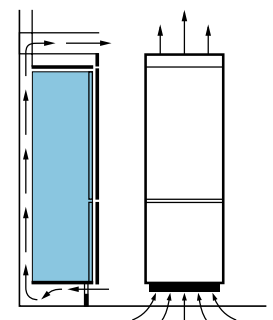
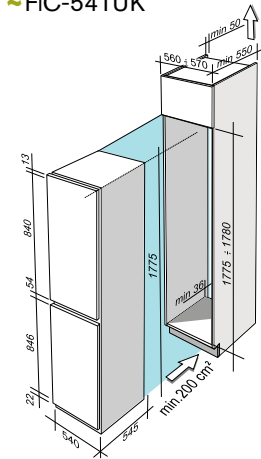

~ FiS-810

~ CiV-820

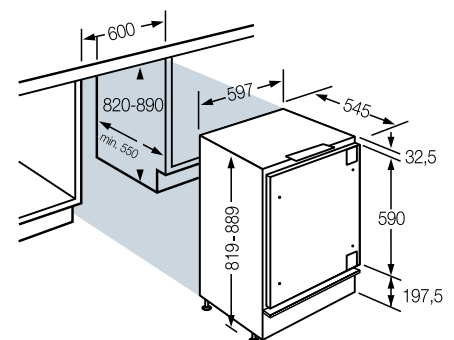

⁺ Climate class SN: Room temperature between +10°C & +32°C

⁺ Climate class N: Room temperature between +16°C & +32°C